

4-Methyl-2,6,7-trioxabicyclo[2,2,2]octane: A Convenient Ring Current Probe

By T. J. BARTON,* R. W. ROTH, and J. G. VERKADE

(*Chemistry Department, Iowa State University, Ames, Iowa 50010*)

Summary ^1H N.m.r. absorptions of the title bicyclic polar molecule undergo pronounced upfield and downfield shifts in the proximity of the shielding cone and deshielding torus, respectively, of carbocyclic and heterocyclic molecules possessing a ring current.

THE normal proton absorptions of the rigid, bicyclic title molecule respond dramatically to aromatic solvent-induced shift (ASIS) effects.^{1,2} The shielding and deshielding at the dipolar extremes in benzene solution are accounted for by

postulation of solvent-solute collision complexes in which some solvent molecules tend to orientate their shielding, negative π -clouds toward the positive end of the dipole, while the relatively positive peripheries of other benzene molecules are attracted by the negative charges of the oxygen lone-pairs which are directed over the orthoformyl hydrogen atom [see Figure 1(a)]. The observations in hexafluorobenzene are opposite to those for benzene [Figure 1 (b)], owing to the much stronger polarity of C-F bonds compared to C-H bonds.¹

TABLE. Differences in proton chemical shift for $\text{HC}(\text{OCH}_2)_3\text{CMe}$ in cyclic solvents^a compared to those in CCl_4 .

Solvent	$\Delta\delta$ from value in CCl_4 (p.p.m.) ^b		
	HC	CH_2	CH_3
Cyclopentadiene ..	0.14 (d)	0.15 (u)	0.37 (u)
Furan ..	0.35 (d)	0.08 (u)	0.42 (u)
Thiophen ..	0.37 (d)	0.21 (u)	0.64 (u)
Tellurophen ..	0.41 (d)	0.21 (u)	0.66 (u)
Pyrrole ..	0.13 (d)	0.35 (u)	0.64 (u)
<i>N</i> -Methylpyrrole ..	0.09 (d)	0.28 (u)	0.54 (u)
Pyridine ..	0.43 (d)	0.07 (d)	0.24 (u)
Nitrobenzene ..	0.13 (d)	0.14 (d)	0.01 (d)
Benzene ..	0.37 (d)	0.27 (u)	0.79 (u)
Cyclo-octatetraene ..	c	0.01 (u)	0.06 (u)
C_6F_6 ..	0.61 (u)	0.02 (u)	0.16 (d)

^a Spectra were obtained on a Perkin-Elmer R20B 60 MHz instrument using solutions containing *ca.* 3% (w/v) orthoformate. ^b (d) and (u) indicate downfield and upfield shift, respectively. ^c Resonance obscured by solvent.

We propose the use of $\text{HC}(\text{OCH}_2)_3\text{CMe}$ as an n.m.r. spectroscopic probe molecule which is diagnostic of the presence of ring currents in solvents possessing substantial π -delocalization since: (a) it detects both the shielding cone and the deshielding torus; (b) both ASIS effects are expected to be strong since each shift stems from separate solvent clusters at opposite ends of the solute dipole; (c) the rigidity of the probe molecule prevents its deformation by solvent interaction; (d) $\text{HC}(\text{OCH}_2)_3\text{Me}$ is easily synthesized in high yield;³ and (e) it is soluble in non-polar as well as polar organic solvents without decomposition.

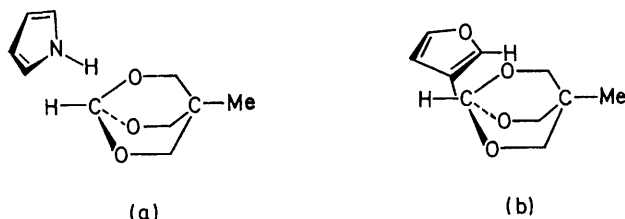

FIGURE 2. Possible orientation of (a) pyrrole and (b) chalcogen heterocyclopentadienes to the negative end of $\text{HC}(\text{OCH}_2)_3\text{CMe}$.

We compare here previous results¹ with those obtained with pyrrole, *N*-methylpyrrole, furan, thiophen, and tellurophen (Table). The methyl protons of the probe molecule experience substantial upfield shifts in thiophen, tellurophen, and the pyrroles when compared with the shift in benzene. The observation of similar shifts in furan and cyclopentadiene is consistent with the concept that furan is only weakly aromatic if at all;⁴ however, the possible role of hydrogen bonding between furan and the probe molecule is difficult to assess.

The downfield shifts at the negative end of the probe molecule dissolved in the chalcogen heterocycles are quite close to those observed in benzene and are about three times larger than those in cyclopentadiene.† These results support the idea that ring currents are present in the

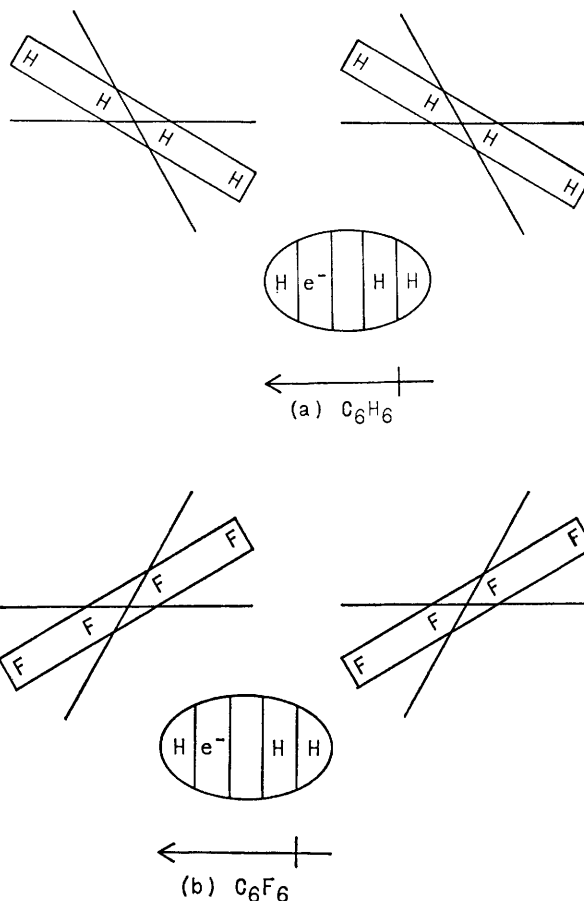

FIGURE 1. Orientation of benzene (a) and hexafluorobenzene (b) to polar solute.

chalcogen compounds. While the presence of ring currents in furan and thiophen has been deduced from other evidence,⁶ a ring current in tellurophen at least equal to that in thiophen as implied in our data is perhaps surprising in view of the principal quantum numbers of the valence shells involved ($n = 5$ vs. 3), but is consistent with the recently reported chemistry of tellurophen.⁷

The small downfield shifts caused by the pyrrole solvents can be rationalized by considering that the conal sheath of oxygen lone-pair density which surrounds the orthoformyl proton in the probe molecule attracts the positive end of the solvent dipole which in both pyrrole and *N*-methylpyrrole (1.80 and 1.92 D,⁸ respectively) is along the C_{2v} axis on the nitrogen side of the ring.‡ Such strongly polar molecules (including PhNO_2 , 3.87 D⁸) may prefer orientation at this end of the probe through the action of dipolar forces [Figure 2(a)] whereas less polar solvents such as furan (0.67 D⁸), thiophen (0.52 D⁸), and tellurophen are better able to adopt a configuration [Figure 2(b)] in which closer approach is possible.

† The small apparent ASIS values in cyclopentadiene are undoubtedly due to anisotropy effects which act in the same direction as ASIS phenomena⁵ and not from π -electron circulation. The cyclopentadiene data emphasise the desirability of comparing the probe n.m.r. data observed in the test solution with values obtained in a closely related solvent in which no ring current can occur.

‡ Pyrrole dipole moment directions are well documented experimentally.⁹ We present evidence elsewhere¹⁰ that the dipole moments of furan and thiophen (and presumably tellurophen) are in the reverse direction.

It is not surprising that cyclo-octatetraene induces negligible shifts in the probe molecule since no ring current is expected. The non-planar and non-rigid conformational properties of this solvent would also interfere with any preferential orientation effects.

This work has been generously supported by the National Institutes of Health.

(Received, 10th July 1972; Com. 1186.)

- ¹ R. D. Bertrand, R. D. Compton, and J. G. Verkade, *J. Amer. Chem. Soc.*, 1970, **92**, 2702.
² J. A. Mosbo and J. G. Verkade, *J. Magnetic Resonance*, in the press.
³ E. J. Boros, K. J. Coskran, R. W. King, and J. G. Verkade, *J. Amer. Chem. Soc.*, 1966, **88**, 1140.
⁴ M. J. S. Dewar, A. J. Harget, and N. Trinajstić, *J. Amer. Chem. Soc.*, 1969, **91**, 6324.
⁵ J. I. Musher, *J. Chem. Phys.*, 1967, **46**, 1219.
⁶ H. A. P. De Jong and H. Wynberg, *Tetrahedron*, 1964, **24**, 515; R. J. Abraham, R. C. Sheppard, W. A. Thomas, and S. Turner, *Chem. Comm.*, 1965, 43; J. A. Elvidge, *ibid.*, 1965, 160; D. W. Davies, *ibid.*, 1965, 258.
⁷ F. Fringuelli and A. Taticchi, *J. Chem. Soc. (C)*, 1972, 199.
⁸ A. L. McClellan, 'Tables of Experimental Dipole Moments,' Freeman, San Francisco, 1963.
⁹ H. Kofod, L. E. Sutton, and J. Jackson, *J. Chem. Soc.*, 1952, 1467.
¹⁰ T. J. Barton, R. W. Roth, and J. G. Verkade, *J. Amer. Chem. Soc.*, in the press.